



HX2 Series

Semi-instantaneous Water Heaters

Description

The HX2 is RECO Commercial Systems' next generation of compact, semi- instantaneous water heaters that can use steam or boiler water as the heating medium. Designed to the guidelines of TEMA, BOCA and IAPMO, these heaters can heat up to 150 GPM water from 40 °F to 140 °F as standard, with higher capacities possible.

At the heart of the control system is the Control Master II® panel with a digital PID controller. The standard Control Master has an easy-to-navigate LED panel for local and remote monitoring and set point adjustment. It accepts remote set point changes and can re-transmit water temperature by analog or digital signals via standard Modbus or available BACnet network communications protocols.

An electrically operated, fast-acting V-ball control valve is used to modulate the flow of the heating fluid. It has a 100:1 rangeability which gives excellent control at all flow rates. Capacitors integrated into the actuator housing close the valve in the event of loss of main power. Soft valve seats provide tight valve shut- off and prevent temperature rises at low load due to valve seat leakage.

The entire package is designed to be a reliable and long-lasting source of hot water. Each component is carefully selected to ensure high performance in even the most demanding applications. All components on the potable water side will be constructed with non-ferrous material. Whether you are heating potable water in a commercial building or process water for an industrial application, you can select a RECO HX2 to do the job. When you specify and install a RECO water heater, you will be provided with a quality product that is a long lasting and trouble-free source of hot water.

Applications

- Schools
- Office Buildings
- Sports Venues
- Hotels
- Industrial Facilities
- Nursing Homes
- Hospitals
- Heat Recovery Systems



Features

- Complies with NSF/ANSI 61 Annex G, NSF/ANSI 372 and conforms with lead content requirements for “lead-free” plumbing as defined in the U.S. Safe Drinking Water Act.
- Can use steam or boiler water as the heating fluid.
- Temperature interlocked controls with secondary over-temperature protection.
- Removable insulation jacket for easy vessel inspection.
- Heating element can be removed with unit in position.
- Operating controls are factory selected, sized, piped and tested to ensure reliable operation.
- Control panel is UL508A listed and has ingress protection to NEMA 4X.
- Vertical and stackable horizontal configurations.
- Steam fired units are supplied c/w strainer and steam trap or optional base-mounted pump-trap package.

1.1 Standard Flow, Pressure, and Temperature Ratings

- Heated water recovery rate 5 to 150 GPM
- Steam supply pressure Up to 100 PSIG
- Cold water inlet pressure Up to 150 PSIG
- Heated water outlet temperature..... Up to 210 °F
- Design rating ASME Boiler & PV Code "U" stamped

Higher flow and pressure ratings available. Contact factory.

1.2 Materials of Construction

The standard materials used with the HX2 Series are shown below.

TABLE 1-1 STANDARD MATERIAL SPECIFICATIONS		
Component	Material	ASME / ASTM Material Specification
Baffles	Naval brass	SB-171-C464
Couplings	Stainless steel	SA-182-F316L (shell)
	Carbon steel	SA-105 (element head)
Element head cap	Carbon steel	SA-516-70
Flanges	Stainless steel	SA-182-F316L (shell)
	Carbon steel	SA-105 (element head)
Hardware	Carbon steel	SA-193-B7 (bolts)
		SA-194-2H (nuts)
Pipe	Stainless steel	SA-312-TP316L (shell)
	Carbon steel	SA-106-B (element head)
Shell / Tank	Stainless steel	SA-312-TP316L
	Copper-nickel alloy	SB 466 (seamless) or SB 467 (welded)
Supports	Carbon steel	SA-36
Tubes	Copper	SB-111-C122 (Double wall)
		SB-75-C122 (Single wall)
Tubesheets	Stainless steel	SA-240-304/304L (inner)
	Carbon steel	SA-516-70 (outer)
	Carbon steel	SA-36 (spacer ring)
Weld cap	Stainless steel	SA-403-316L (formed 2:1 head)
	Copper-nickel alloy	SB -171-C706

1.3 Heat Transfer Surface Area

Technical data for the standard HX2 heating bundles are given below. Note that tube bundles are designed in standard "U" tube arrangement, with the number of tube openings seen at the tubesheet double the amount of individual tubes actually used.

TABLE 1-2 TUBE BUNDLE HEAT TRANSFER DATA						
HX2 Size	Single Wall Tubes			Double Wall Tubes		
	Nominal O.D.	No. of Tubes	Surface Area (ft ²)	Nominal O.D.	No. of Tubes	Surface Area (ft ²)
06 030	1/2"	28	17.6	3/4"	13	11.5
06 036			21.3			14.1
08 030	1/2"	51	31.7	3/4"	24	21.1
08 036			38.3			25.9
10 030	1/2"	88	53.6	3/4"	41	36.0
10 036			65.1			44.0
12 030	1/2"	133	82.1	3/4"	59	51.5
12 036			99.5			63.1

1.4 HX2 Rating Charts

To select an HX2 the steam pressure (PSIG) available, amount of water (GPM) to be heated, and amount of heating (°F) to be done must be known. Heating is commonly specified in increments of 80 °F (40 °F to 120 °F) or 100 °F (40 °F to 140 °F).

The first step is to locate the correct chart from the four that follow. Next locate the appropriate Steam Supply Pressure available (PSIG) along the X-axis, and the amount of water to be heated (GPM) along the Y-axis. Where the two intersect, find the rating curve corresponding to those conditions. If this intersection lies between two rating curves, choose the larger unit (higher curve).

Notes:

1. For copper-nickel tubes, de-rate the copper tube ratings shown by 20%.
2. The ratings curves shown assume a tube bundle fouling factor of 0.00025 (hr. x ft² x °F / BTU).
3. For applications with water as the heating source, contact RECO Commercial Systems Sales Department.

1.5a Rating Charts for 80 °F Heating

40 °F to 120 °F - Single Wall Copper Tubes

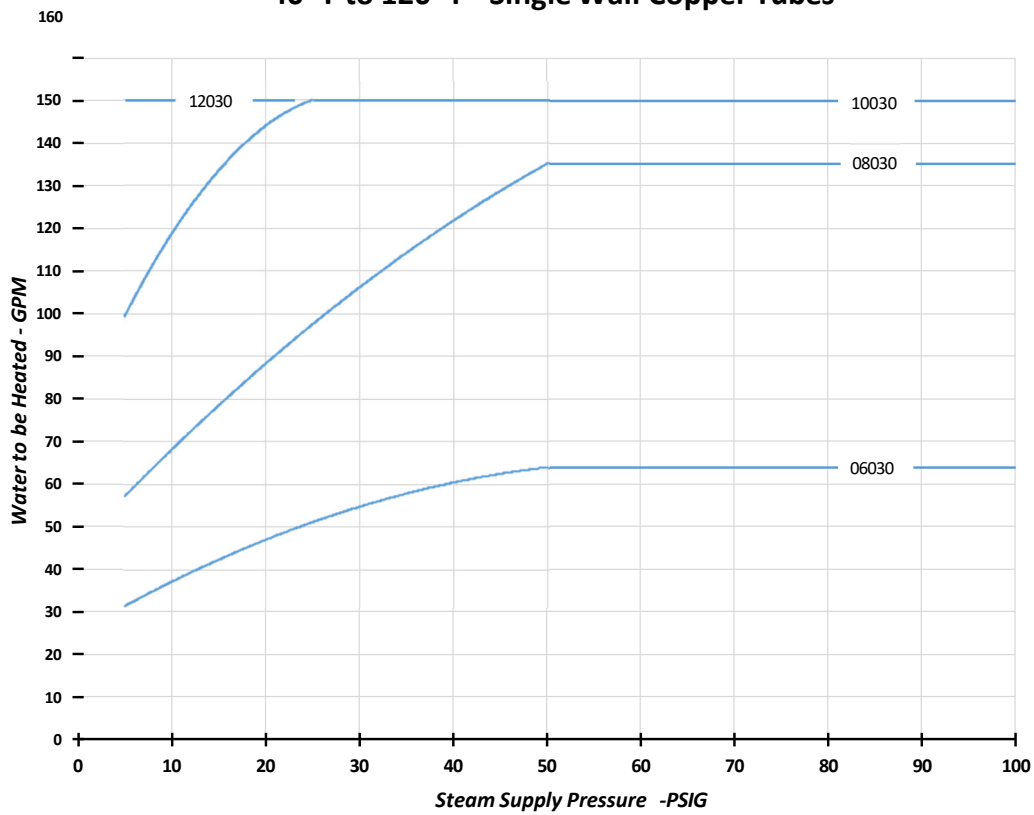

40 °F to 120°F - Double Wall Copper Tubes

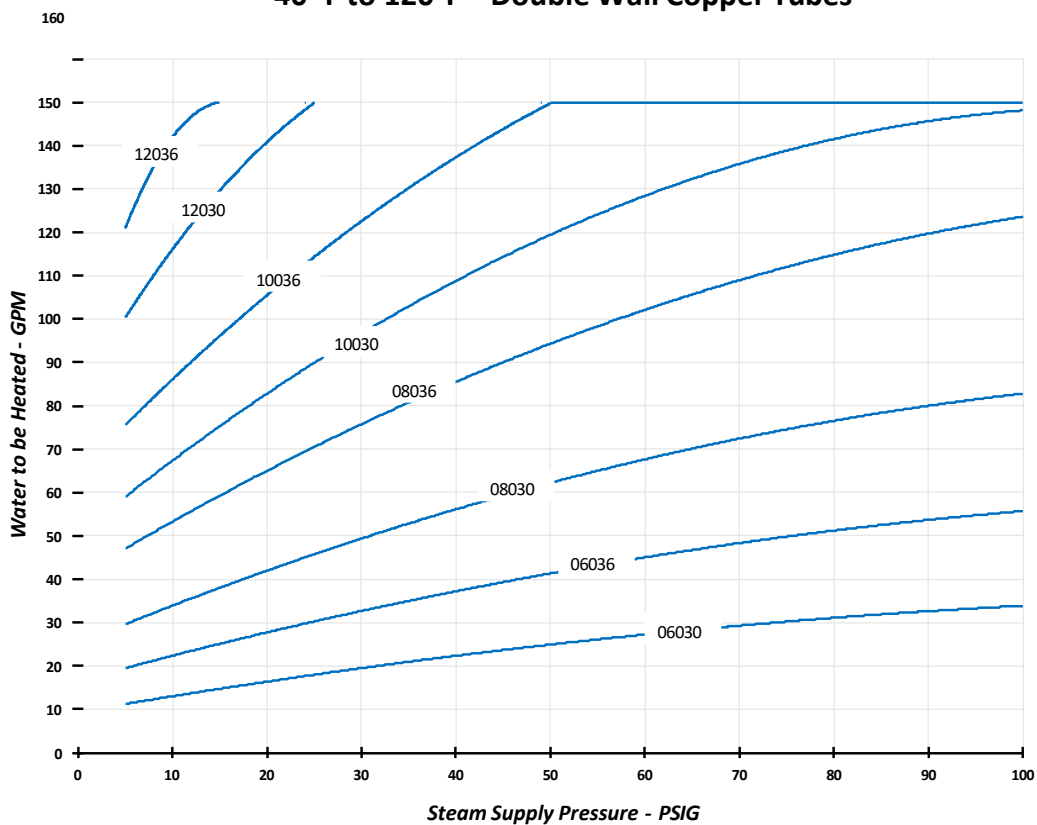

1.5 b Rating Charts for 100 °F Heating

40 °F to 140 °F - Single Wall Copper Tubes

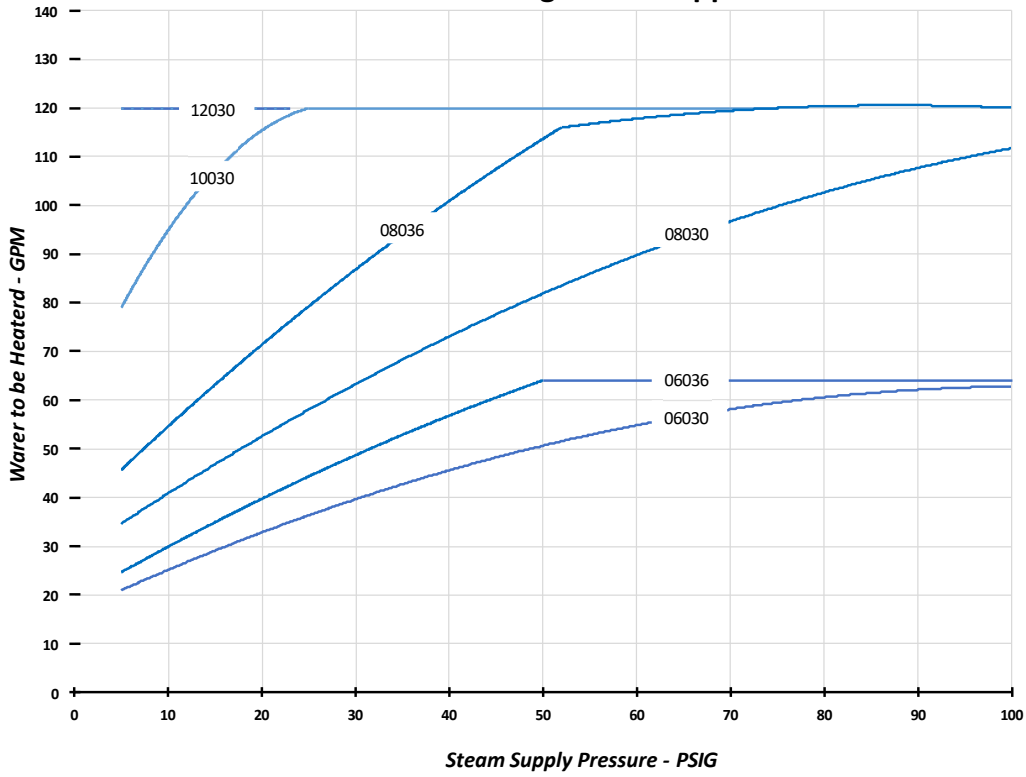

40 °F to 140 °F - Double Wall Copper Tubes

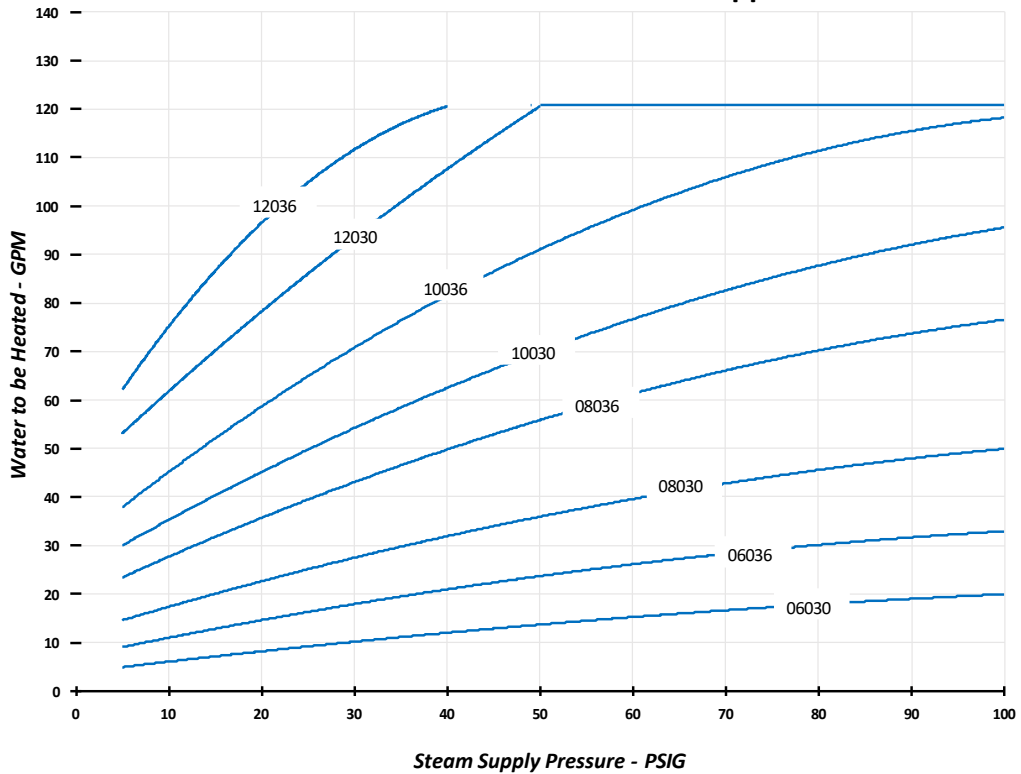

1.6 General Arrangement Dimensions and Weights – Vertical Units

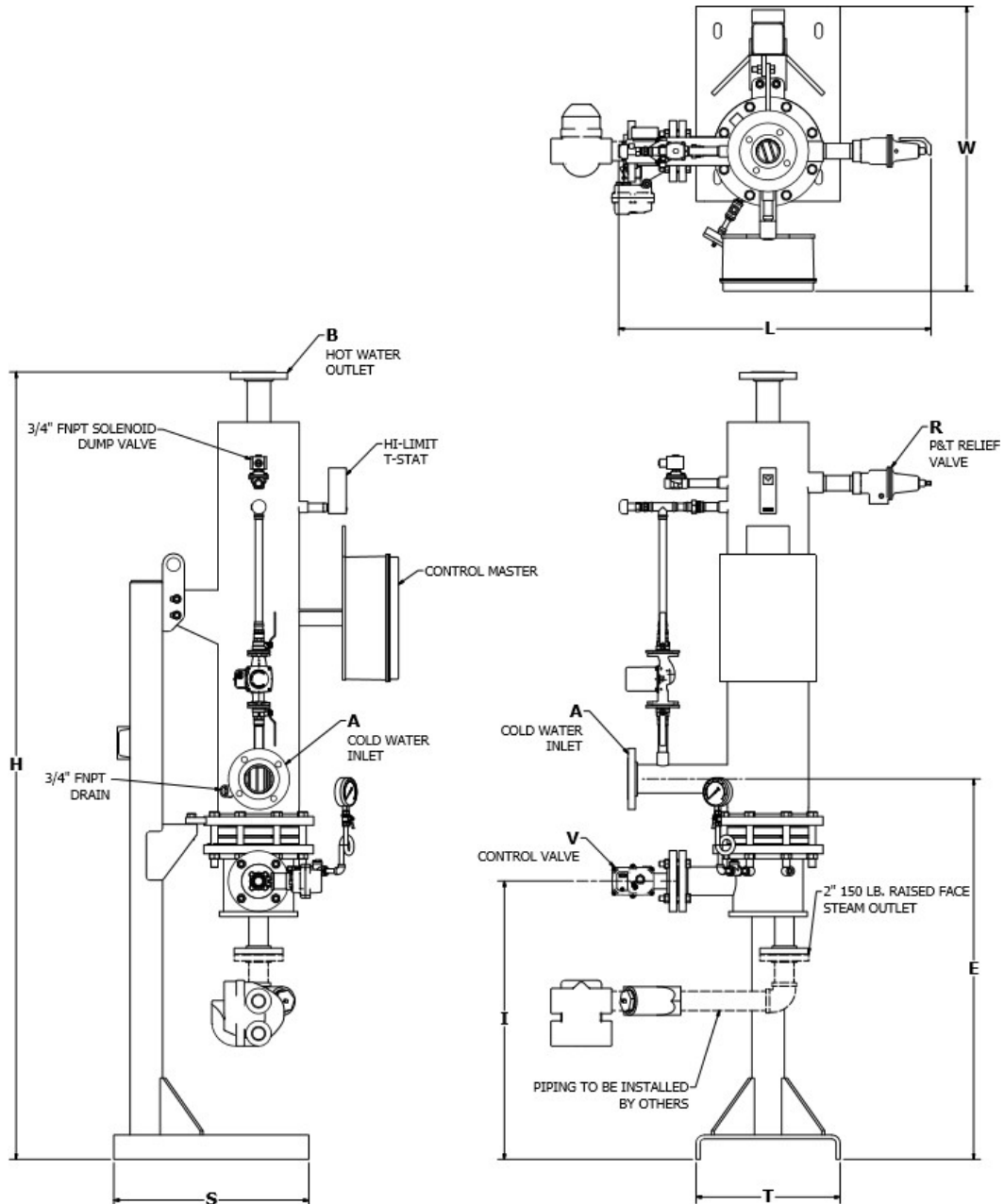

TABLE 1-3 VERTICAL UNIT DIMENSIONS

Basic Size	A	B	E	H	I	L	R	S	T	V	W	Wt. (lbs.)
06030 / 06036	2"	1 1/2"	46.75	95.0	34.25	32.0	3/4" NPT	24.0	17.75	1" FNPT / 1.25" FNPT	33.0	930 / 950
08030 / 08036	3"	2 1/2"	46.75	97.0	34.25	38.0	1/2" NPT	24.0	17.75	1" FNPT / 1.25" FNPT	35.0	1,125 / 1,155
10030 / 10036	4"	3"	46.75	99.0	33.75	49.0	1/2" NPT	24.0	17.75	2 1/2" 150 Lb. RFSO	37.0	1,380 / 1,420
12030 / 12036	4"	3"	46.75	100.0	33.75	51.0	1/2" NPT	24.0	17.75	3" 150 Lb. RFSO	39.0	1,655 / 1,705

Notes:

1. Dimensions "A" and "B" are nominal sizes for ANSI 150 lb. raised face, slip on (RFSO) flange.
2. All dimensions in inches, unless noted otherwise.
3. Weights shown are net empty weight for a standard HX2 unit. Crating or shipping materials not included.

1.7 General Arrangement Dimensions and Weights – Horizontal Units

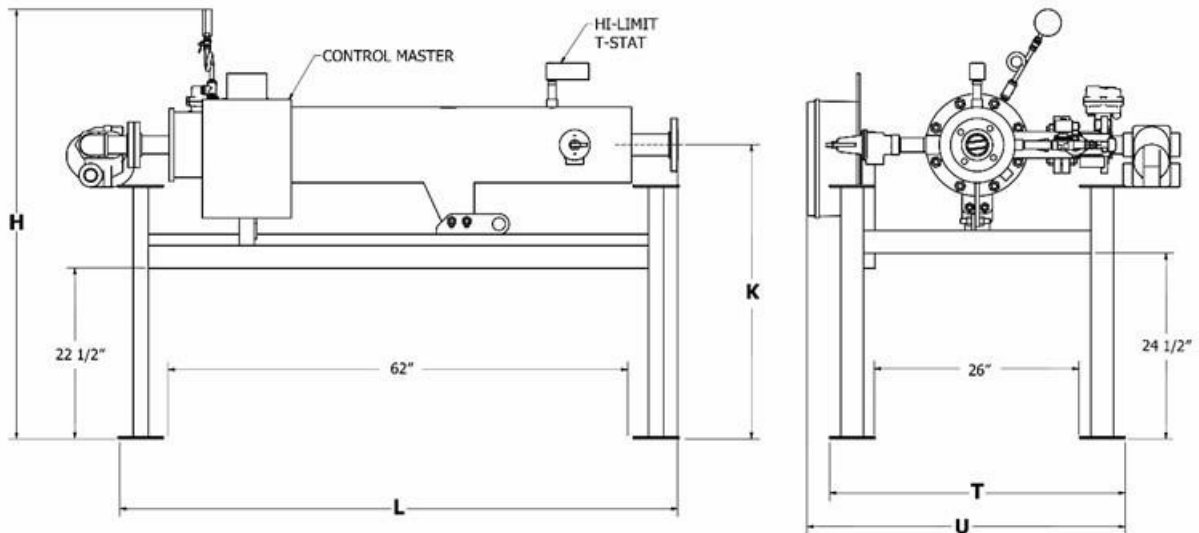
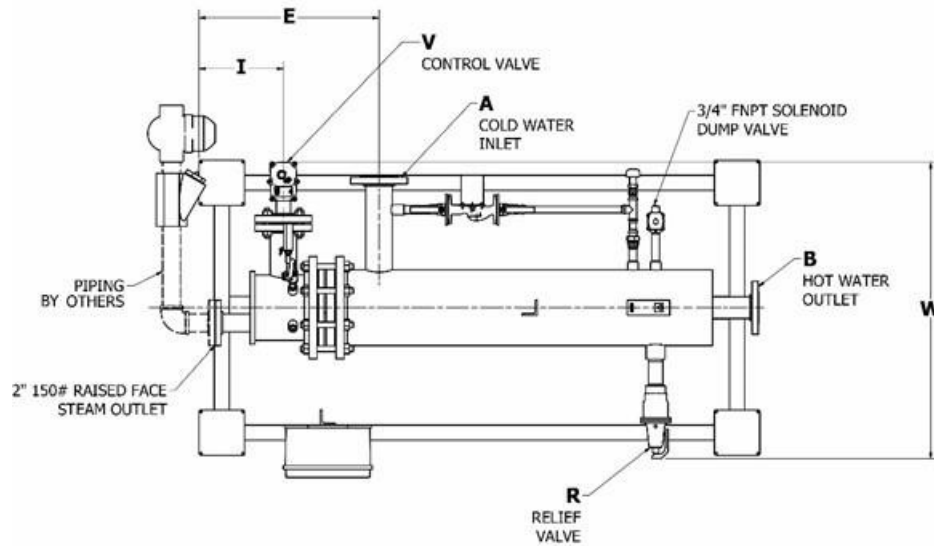

TABLE 1-4 HORIZONTAL UNIT DIMENSIONS

Basic Size	A	B	E	H	I	K	L	R	S	T	U	V	W	Wt. (lbs.)
06030 / 06036	2"	1 1/2"	23.75	60	34.25	37.75	71.75	3/4 FNPT	24	39	41	1" / 1.25" FNPT	33	985 / 1,005
08030 / 08036	3"	2 1/2"	23.75	61	34.25	38.75	73.5	1.5 FNPT	24	39	41	1.5" / 2" FNPT	35	1,180 / 1,210
10030 / 10036	4"	3"	23.75	62	33.75	39.75	74	1.5 FNPT	24	39	41	2.5" 150 Lb. RFSO	37	1,435 / 1,475
12030 / 12036	4"	3"	23.75	63	33.75	40.75	77	1.5 FNPT	24	39	41	3" 150 Lb. RFSO	39	1,710 / 1,765

Notes:

1. Dimensions "A" and "B" are nominal sizes for ANSI 150 lb. raised face, slip on (RFSO) flanges.
2. All dimensions in inches, unless noted otherwise.
3. Weights shown are net empty weight for a standard HX2 unit. Crating or shipping materials not included.
4. Allow "L" dimension plus 6 inches for tube bundle removal clearance.

1.8 HX2 Configuration and Ordering Code

The following Configuration and Ordering Code defines the **HX2** and can be found on the unit nameplate. When inquiring about a HX2 this code must be used. Doing so enables us to handle requests quicker and assure the correct unit is being discussed.

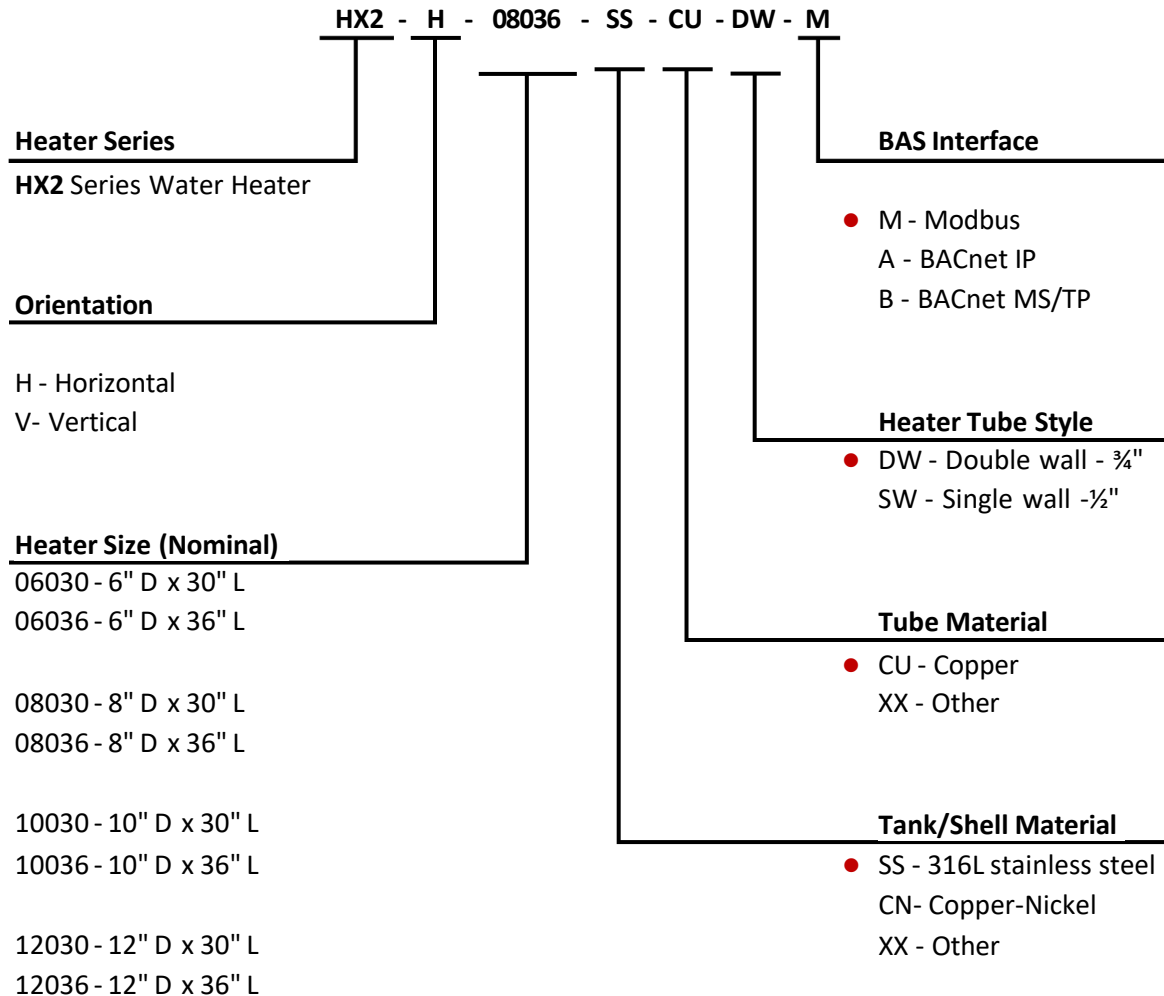

● *Denotes standard configuration*

1.8 a Sample Selection:

The selected unit is a RECO HX2 series water heater model **HX2-H-0836-SS-CU-DW-M** horizontal water heater with 8" diameter x 36" long heating element, 316L stainless steel tank, ¾" copper double-wall tubes, and standard Modbus® communication interface with the building automation system.

1.9 **How to Specify**

The water heater shall be a **RECO Series HX2** capable of heating (x) GPM of water from 40 °F to (x) °F with (x) PSIG of incoming saturated steam. The unit shall be an ASME Code "U" stamped pressure vessel rated for safe operation to 150 PSIG and be in full accordance with the Section VIII, Division 1 of the latest ASME code. It shall be constructed with a 316L stainless steel tank, passivated for added corrosion resistance to ASTM A380 and A967 requirements, with stainless steel connections and 3/4" O.D. copper tubes. All steam and condensate piping shall be carbon steel, welded or threaded as appropriate.

The copper heating tubes shall be double walled with a vented leakage path between the heating medium and water being heated to prevent contamination of the water. All wetted parts on the water (heated) side shall be lead-free and comply with NSF Standard 61 and conform to all requirements of the U.S. Safe Drinking Water Act.

The heating bundle shall include an ASTM 304L stainless steel inner tube sheet, carbon steel spacer ring, and carbon steel outer tube sheet. For added protection and durability the element head and support stand shall be powder coated to a minimum of 5 mils dry film thickness (DFT). The heater tank shall be mounted on a rigid steel support skid and insulated with a heavy-duty silicon coated fiberglass outer jacket meeting the latest ASHRAE requirements. The tank shall also allow for easy removal and inspection of the heating bundle without the need for dismantling of the heater from the support stand.

The unit shall include a mechanical pressure/temperature (P/T) relief valve, solenoid dump valve at the tank controlled by an independent, high temperature limit switch, and automatic, fail-closed, steam inlet control valve. A continuously operating recirculation pump shall also be provided to ensure a uniform temperature distribution across all temperature sensors while preventing the build-up of sediment in the tank bottom or on the heating tubes.

An electrically operated, fast-acting V-ball control with full 100:1 rangeability shall be used to modulate the flow of heating medium to the unit. It shall provide accurate control at all heating conditions and the valve actuator shall be tied into the PID control loop to fail closed in the event of a loss of power.

The control panel shall be a complete, pre-assembled and pre-wired unit housed in a NEMA 4 enclosure with a programmable temperature controller and easy to navigate LCD panel capable of local or remote set point and alarm. It shall incorporate a PID control loop that sends a modulating signal to the steam control valve. Valve signaling shall be 0-10 VDC as standard. The control panel shall utilize RS485 communication interface for full compatibility with Modbus® and BACnet® IP or MS/TP building automation communications protocols.

The HX2 Series water heater shall carry a full **5-year warranty** against defects in material and workmanship of the pressure vessel. The tube bundle shall carry a full **1-year warranty** against failure due to defects in material, workmanship, thermal shock or mechanical failure.