

# **STORAGE TANKS**

For Domestic Water Systems



***INSTALLATION, OPERATION,  
AND MAINTENANCE MANUAL***

**RECO**  
**USA**  
The Water Heater and Pressure Vessel Experts

# ST2 SERIES STORAGE TANKS

## FOR DOMESTIC WATER SYSTEMS

### SECTION 1 - GENERAL INFORMATION

---

#### 1.1 **Overview**

This Installation, Operation, and Maintenance (IOM) is intended to be a guide for all RECO USA standard commercial water tanks.

Covered in this manual are our **ST2**<sup>®</sup> Series - Storage Tanks

#### 1.2 **Technical Support**

For technical support, warranty, or shipping, issues contact us at:

- **RECO USA**  
1839 Dunbar Road  
Cayce, SC 29036  
[www.reco-usa.com](http://www.reco-usa.com)
- Phone: (803) 794-3360

#### 1.3 **Disclaimer**

All installation, operation, and maintenance work should only be attempted by authorized personnel knowledgeable in proper plumbing and electrical practices, and thoroughly trained in working with pressurized hydronic systems.

RECO USA is not responsible for any damage to the tank resulting from improper installation, maintenance, or operation of the tank. In addition, RECO USA is not responsible for any injury to personnel or product damage due to improper installation, maintenance, or operation of the tank or practices contrary or not consistent with those described in this IOM manual

This Installation, Operation, and Maintenance (IOM) manual is current as of the date issued, and RECO USA reserves the right to update, modify, amend, or change the information contained herein at any time without prior notice and without obligation to notify anyone of such changes.

# ST2 SERIES STORAGE TANKS

## FOR DOMESTIC WATER SYSTEMS

### SECTION 2 - INSTALLATION

---

#### 2.1 Unpacking and Inspection

- a. RECO USA commercial tanks are provided with integral lifting lugs to safely lift and move the tank(s) into place. A tank should only be lifted by using the lifting lugs provided, as improper lifting or rigging will result in damage to the unit.
- b. After the unit has been unloaded it should be carefully examined for any damage that may have occurred in transit. If damage is found a claim must be immediately made with the common carrier who delivered the unit(s). Also notify RECO USA and/or your local authorized sales as well.
- c. All tanks must be installed and operated immediately after receipt. RECO USA does not include any special preservation for long term storage, and assumes no responsibility for storage deterioration after shipment unless explicitly agreed to in writing beforehand.

#### 2.2 Installation

- a. The tank should be installed with adequate room around it for servicing. Provide at least 3'-0" of free and unrestricted access in all directions for inspection and maintenance.
- b. The tank must be anchored securely to a supporting base capable of withstanding the loads imposed by a fully filled tank. It should also be on a level surface with no more than 0.5° slope to permit proper drainage and sight glass and/or level transmitter accuracy.
- c. Mounting and installation must conform with all applicable national and local code requirements for the specific installation site.
- d. In areas prone to seismic activity, extra care should be taken that the tank mounting satisfies all applicable codes for seismic activity.
- e. All water, air, and/or drain lines should be installed in accordance with good engineering practices. Note that the ASME code requires there be no reduction in pipe size for any of these, and no valves or other restrictions can be introduced in the piping from the relief valve.
- f. After mounting the unit in place, connect the main inlet piping to the tank, and then the main tank discharge piping from the tank. The locations of these are indicated on the General Arrangement drawing (see Appendix A).
- g. Pipe the relief valve, overflow line, and/or drain line separately to a suitable drain. Do not install a valve in the relief valve or overflow lines, as that would defeat the purpose of those lines.
- h. A manual shut off valve of the same size as the main tank inlet line should be installed upstream of main tank inlet, and kept in the closed position until the installation is complete. A shut off valve of the same size as the outlet line should also be installed at the outlet connection. Together, these two valves will isolate the tank as needed.

- i. All tanks are tested at the factory prior to shipment. However, things can loosen during transit and/or installation, resulting in leaking connections. Once installed, all piping and connections should be re-inspected, and any leaks or damage corrected at that time. Follow the recommended Bolt Tightening Sequence and Torque Values Guidelines shown in Section 2.3 below.
- j. An ASME certified pressure or pressure/temperature relief valve (by others) must be installed on the tank using the connection provided. While the pressure rating of the relief valve can be lower than the tank's rating, it must never exceed the working pressure of the tank.
- k. An inlet strainer (by others) is strongly recommended at the main tank inlet to keep the tank free of debris and other contaminants.
- l. All joint compounds, gaskets, and/or thread sealant used on piping connections to and from the tank should comply with all applicable national and local code requirements for the specific installation site and suitable for the application

**2.3 Flange Bolt Tightening Sequence and Torque Values**

The following bolt tightening pattern and torque values should be used whenever tightening a tank flange. A recommended practice is to do this in (3) steps leading up to the final torque values, rather than attempting to complete this in one sequence.

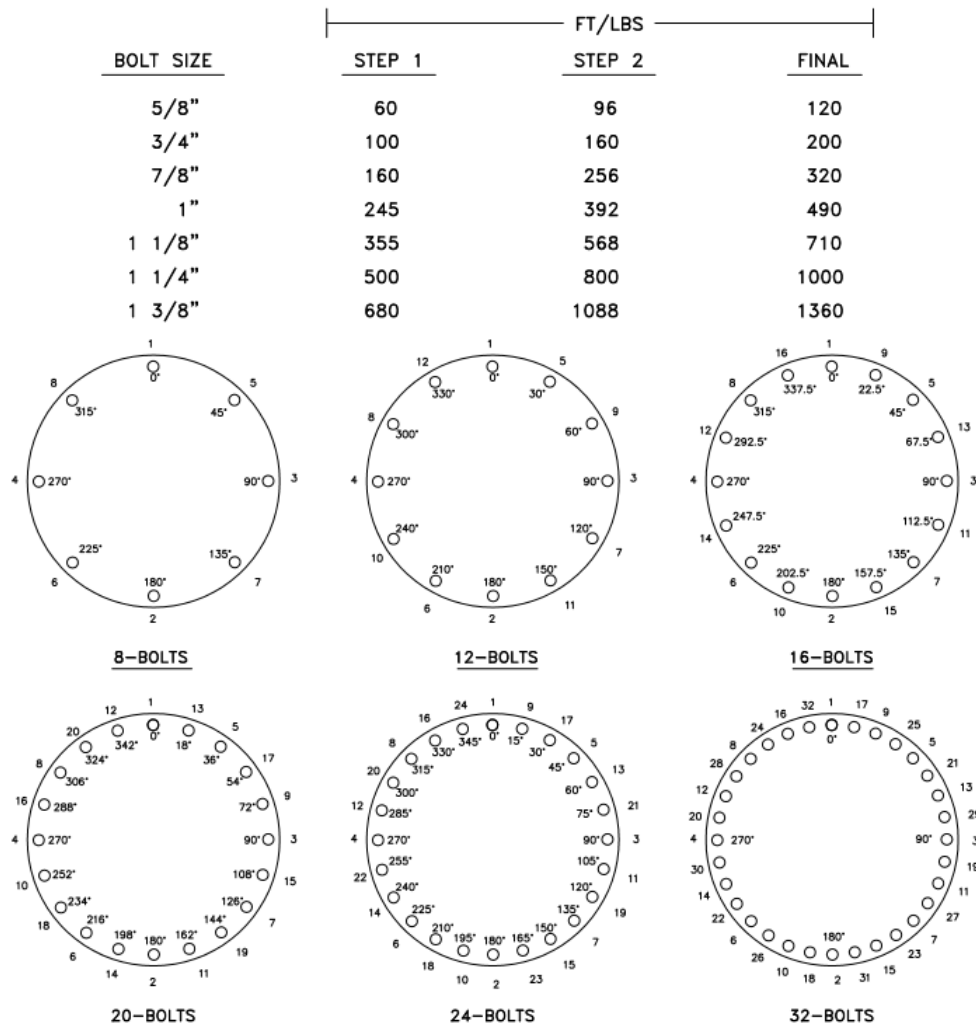

**Fig 2.1 – Bolt Tightening Sequence and Torque Values**

# ST2 SERIES STORAGE TANKS

## FOR DOMESTIC WATER SYSTEMS

### SECTION 3- OPERATION

---

#### 3.1 Start Up

After completing the installation sequence described in Section 2, to start up the tank the following steps should be taken:

- a. Begin by assuring all inlet and outlet valves and drain connections are closed.
- b. Turn on any electrical power and compressed air supply to the tank.
- c. Slowly open the main inlet valve to the tank, along with any air vent or spare connection, to allow the tank to fill.
- d. Allow the tank to slowly fill to the desired level.
- e. Check that all auxiliary components such as sight glasses, safety relief valves, gauges, overflow connections, etc. are unobstructed and functioning properly and are leak-free.
- f. Open the main outlet valve from the tank to connect the tank to its system. Doing this may result in a lowering of the tank level as water leaves the tank to fill the empty outlet piping and system. If this occurs, repeat Step 3.1.d until the desired steady state water level is reached.
- g. Use the vent connection or release lever on the tank relief valve to vent the tank and/or evacuate any excess compressed air in the tank until the desired pressure is reached.
- h. Check again for any leaks, as tightening of gasketed joints may be required after tank has been filled and, in the case of hot air or water, the tank begins to warm up.
- i. Never allow the tank to operate beyond its design conditions (see Appendix A).

#### 3.2 Shut Down

To shut the tank down, follow the sequence described below:

- a. Turn off any electrical power to the tank control panel.
- b. Close the inlet control valve to cut off incoming water to the tank.
- c. Close the discharge valve at the tank outlet.
- d. Close the air inlet valve and any other valves to completely isolate the tank from the system.
- e. With the tank now isolated by the valving, and de-energized electrically, allow sufficient time for the tank contents to cool. For insulated tanks this may take some time.
- f. Open the tank vent connection or lift the release lever on the tank relief valve to evacuate any compressed air in the tank. Continue to do this until the tank interior is brought to atmospheric pressure.
- g. Once the tank is at ambient temperature and atmospheric pressure, and the tank is vented, open the tank drain valve to drain the contents of the tank down to the desired level.

# ST2 SERIES STORAGE TANKS

## FOR DOMESTIC WATER SYSTEMS

### SECTION 4- INSPECTIONS AND MAINTENANCE

RECO USA tanks require very little maintenance. However, to maximize the useful life of the tank, we recommend all tanks be inspected regularly and any issues discovered be promptly addressed.

#### 4.1 Inspections

We recommend the following inspection intervals be performed on a regular basis:

TABLE 4-1 RECOMMENDED INSPECTION INTERVALS				
Item	At Start Up	Monthly	Quarterly	Annually
Air supply / air vent	✓	✓		
Drain connection	✓	✓		
Fittings and gaskets	✓	✓		
Main inlet and outlet shut off valves	✓	✓		
Manways / access ports	✓	✓		
Piping runs / inlet strainer	✓		✓	
Pressure / temperature gauge	✓		✓	
Pressure / temperature relief valve	✓		✓	
Sight glass / level transmitter	✓		✓	
Support stand and base	✓		✓	
Tank body	✓		✓	
Tank interior				✓

#### 4.2 Maintenance

- a. If leaks or faulty components are detected, they should be immediately repaired or replaced. Before shutting the tank down, the operator should also be familiar with this Installation, Operation, and Maintenance Manual in its entirety before proceeding.
- b. Never break a gasketed surface, or threaded connection while the tank is in operation or under pressure. Instead, the tank must first be isolated, de-energized, and drained. Allow adequate time for the tank to cool before attempting any further work. See Section 3.2.
- c. For threaded connections that are disassembled, the threads must be thoroughly cleaned and new pipe joint compound and/or sealant tape be used. Never reuse old pipe joint compound or sealant tape.
- d. For any flanged connection that is disassembled or manway that is removed, a new gasket must be used to assure a proper, leak-free connection. Never reuse an old gasket, regardless of its physical appearance.

- e. To seal the manways opening after inspection and/or maintenance, place a new gasket and the existing manway cover, crab brackets, two bolts and two nuts into position. Turn the nut clockwise until it is snug against the crab, and then turn it 1 to 2 revolutions further. Fill the tank using the procedure described in Section 3.1 and allow pressure to build to help seal the gasket. Some leakage may occur at this point, but as the gasket seats the leakage will eventually stop.
- f. After the leaking has stopped, turn the bracket nuts one further revolution. At this point there may be some minor seepage evident, but after a few minutes that should stop.
- g. If the seepage continues, drain the tank (see Section 3.2) and remove the gasket, cover, crab brackets, bolts, and nut. Inspect these, along with the manway ring, for any damage and repair or replace as appropriate. Repeat the above procedure using a new gasket.
- h. Never try to seal the cover solely by continually tightening the crab bracket nut. Doing so may cut or crush the gasket, which will ruin it and make further sealing impossible.

### **4.3 Lining Repair – Cement Lined Tanks**

- a. Shut the unit down by following the procedures described in Section 3.2.
- b. Upon inspection of a cement lined tank, if there are areas where the cement lining has separated from the steel tank wall, or where there are cracks or voids visible in the lining, mark these with chalk. Often the extent of lining separation can be determined by tapping in the general area with a wooden rod, and listening for a hollow sound.
- c. Wearing personal protective equipment appropriate for the task, remove the defective area with a hammer and chisel. Check all perimeter edges for the repair area to be sure all loose material has been removed.
- d. Once the loose cement has been removed, clean the exposed steel of any rust or scale.
- e. To complete the repair, mix an appropriate amount of cement (consult RECO USA for the correct cement specifications needed) to a putty-like consistency. Wet the area to be repaired with clean water.
- f. Using a cement trowel, fill the area to be patched to about 2" of fill, or until it is even with the surrounding areas, and feather the edges with the adjoining, non-repaired surfaces. Keep the cement moist until it has hardened.
- g. Do not allow the cement to dry out too quickly, and do not apply any petroleum-based curing agent to the cement.
- h. Close the tank, clean off all internal surface areas and refill with water per Section 3.1.

# APPENDIX C – STORAGE TANKS

## CONFIGURATIONS, RATINGS, AND DIMENSIONS

RECO USA’s ST2 storage tanks are designed to store potable water for domestic use. They are carbon steel vessels with an interior lining to prevent corrosion. This is a more economical approach than using a higher-grade, corrosion-resistant alloy, such as stainless steel or Cu-Ni, without a lining.

### A.1 Standard Ratings

- Capacity .....Up to 1,000 gallons.
- Ratings .....Up to 150 PSIG max pressure, 250° F max operating temp.
- Specifications.....Designed to ASME B & PV Code Section VIII, Division I.
- Materials .....ASTM SA-516-70 carbon steel tanks as standard.
- Connections.....All connections over 2½” are ANSI 150 lb. RFSO flanges.
- Interiors.....Sandblasted per SSPC-SP 10 with an NSF 61 compliant cement lining.
- Exteriors .....Sandblasted per SSPC-SP 6 and coated with a red oxide primer.

### A.2 ST2 Configuration and Ordering Code

The following Ordering Code defines the **ST2** storage tank. When inquiring about an ST2 this Ordering Code, along with all available nameplate data, should be used. Doing so will help expedite any requests for technical support.

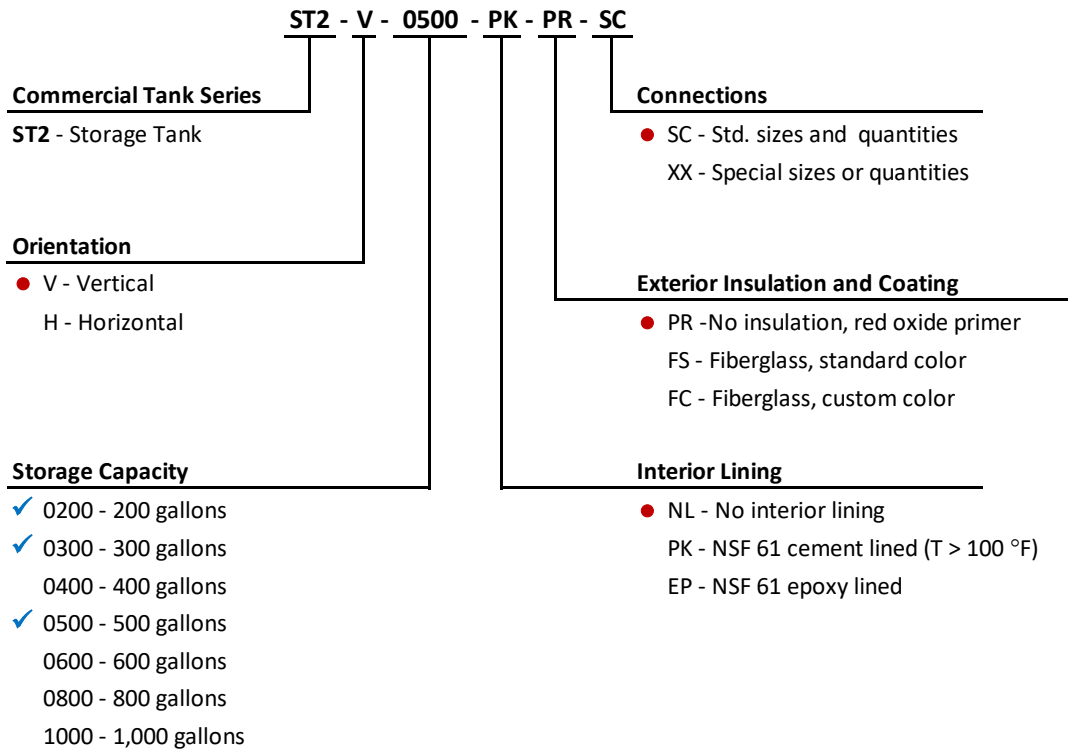

• Denotes standard configuration

✓ Tanks normally stocked for quick delivery



**A.3 ST2 General Arrangement Drawing**

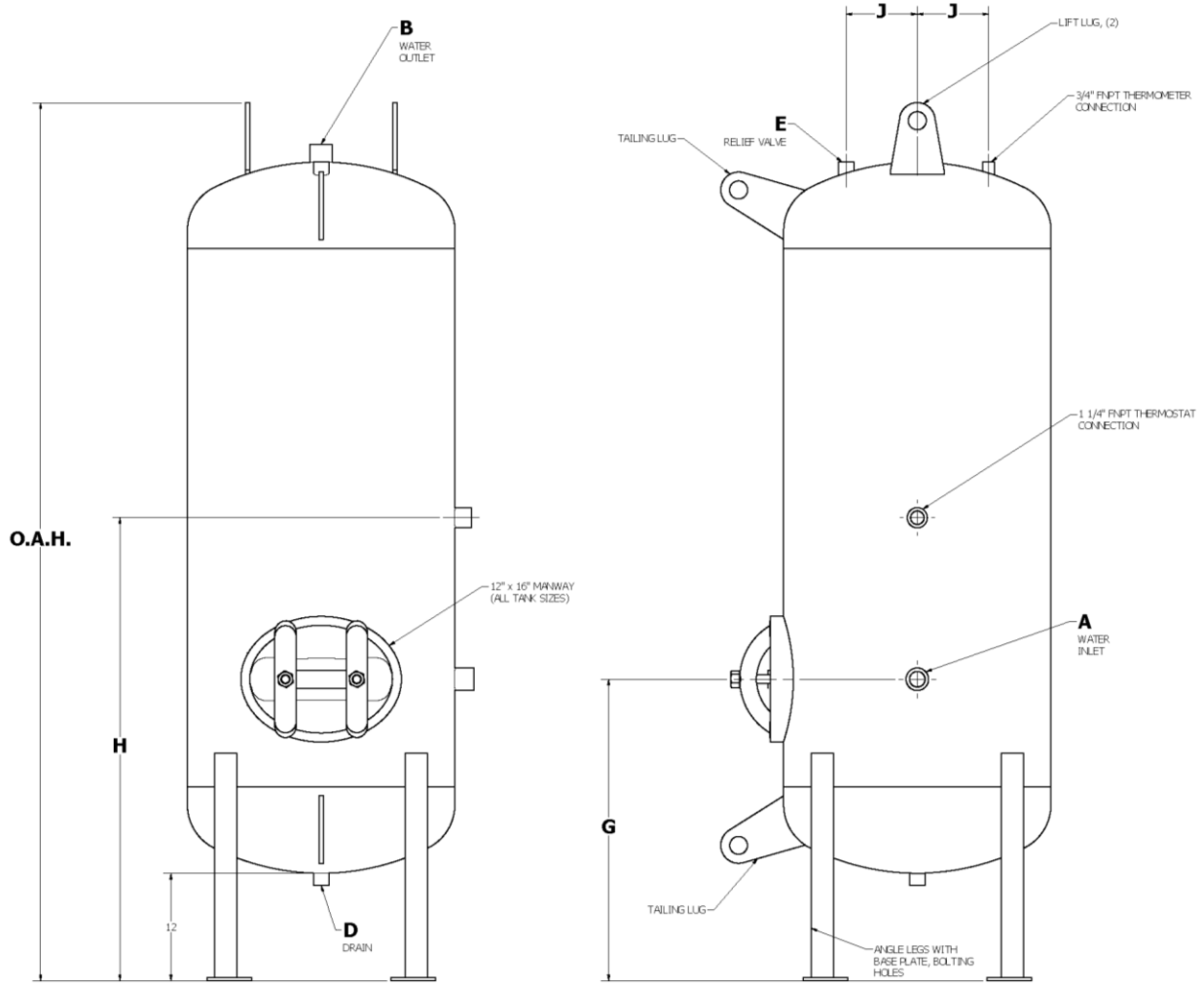

**Table A-1 - ST2 Tank Dimensions**

Capacity (Gals.)	A & B	D	E	G	H	J	OAH	Nominal Size	Unlined / Lined Weight (lbs.)
200	1-1/2" FNPT	1" FNPT	1" FNPT	33-5/8"	51-5/8"	8"	97-7/8"	30" x 60"	697 / 1,107
300	1-1/2" FNPT	1" FNPT	1" FNPT	33-5/8"	69-5/8"	8"	133-7/8"	30" x 96"	949 / 1,535
400	1-1/2" FNPT	1-1/2" FNPT	1-1/2" FNPT	36-5/8"	51-5/8"	10"	97-1/4"	42" x 54"	1,053 / 1,646
500	1-1/2" FNPT	1-1/2" FNPT	1-1/2" FNPT	36-5/8"	60-5/8"	10"	115-1/4"	42" x 72"	1,230 / 1,948
600	1-1/2" FNPT	1-1/2" FNPT	1-1/2" FNPT	36-5/8"	69-5/8"	10"	133-1/4"	42" x 90"	1,407 / 2,250
800	2" FNPT	2" FNPT	1-1/2" FNPT	38-5/8"	71-1/4"	12"	136-1/2"	48" x 90"	1,881 / 2,878
1,000	2" FNPT	2" FNPT	1-1/2" FNPT	38-5/8"	86-1/4"	12"	166-1/2"	48" x 120"	2,302 / 3,537

© 2021 RECO USA. All Rights Reserved.

All trademarks are the property of RECO USA, and unauthorized use of these trademarks, as well as the information presented herein, is expressly prohibited and constitutes a violation of the intellectual property rights of RECO USA.

Visit us at [www.reco-usa.com](http://www.reco-usa.com)

**ST2 SERIES TANKS – IOM - REV. 1 / JANUARY 2021**

